

LUMBERJACK TOOLS

 *Made in the U.S.A.* 

As with any new hobby or project, it will take time to get good at using our tool and building furniture. You must first have a plan or sketch of what you want to build, along with a tools and materials list before you begin. This will allow you to obtain the raw materials, tools and other items you'll need before you get started and realize you forgot something.

Another important issue is reading the natural twist, stress or other deformities in the logs and using these skills to your advantage allowing your pieces to become more unique as your abilities grow. Also as important is to not over complicate your first few pieces so you can have a "positive" experience.

Thank you for purchasing our tools!

Figure: 1

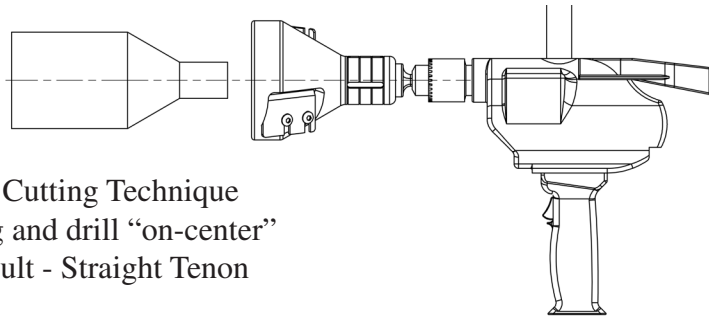

Proper Cutting Technique

- Log and drill "on-center"
- Result - Straight Tenon

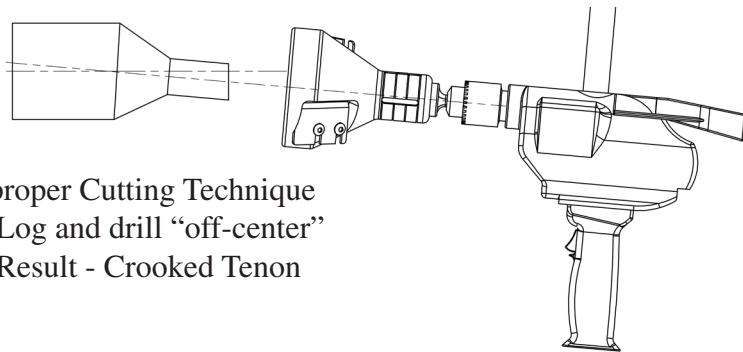

Improper Cutting Technique

- Log and drill "off-center"
- Result - Crooked Tenon

"In-Sight" Measurement System

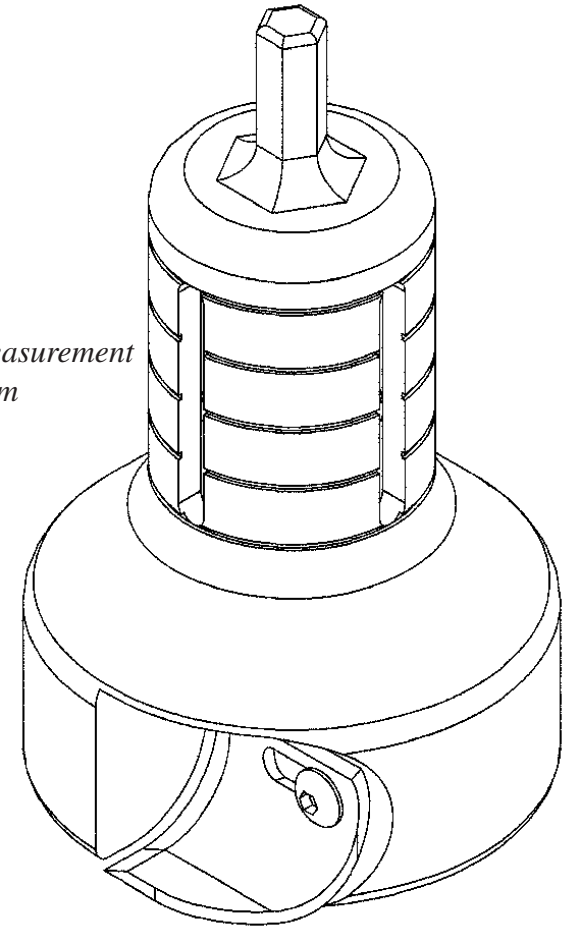

PRO SERIES – Dual Blade Tenon Cutters

Lumberjack Tools, Inc.

Distributed By:

Schroeder Log Home Supply, Inc.
1-800-359-6614 www.loghelp.com

MODELS:

Pro Series TTR0500
Pro Series TTR0625
Pro Series TTR0750
Pro Series TTR1000
Pro Series TTR1500
Pro Series TTR2000

Thank you for purchasing our Dual Blade - Pro Series Tenon Cutter!

Lumberjack Engineers, along with our craftsmen, have designed the safest, easy-to-use self-centering tenon cutter on the market. By combining old-world skills, along with DFMA principles and CNC technology, we've eliminated the issues of off-center tenons and side-load cutting associated with single-blade designs.

We've added value with the dual-blade technology which will cut the tenon in half the time, and the two blades stay sharper, longer. The In-Sight measurement system allows the craftsmen to cut the tenon to length without the process of measuring with a tape measure each and every piece before it is worked.

Our solid billet of aircraft-grade aluminum is designed to last a lifetime under normal operating conditions. The aluminum body is CNC machined to ensure precise cutting each and every time. The blades are stamped, heat treated and precision ground to provide years of service when properly maintained.

Before beginning any project, carefully read and follow all safety and operational instructions for any tools or devices you will be using. Failure to follow all safety instructions may cause bodily harm to yourself or those around you. If you feel uncomfortable using our tenon cutter or any other tools, stop immediately. We assume no responsibility for injury caused to the operator, bystander or tools used in conjunction with the use or misuse of our tenon cutters.

WARRANTY:

Our lifetime guarantee covers the tool body and shank. The blades are covered for 90 days from the date of purchase for breakage under normal working conditions. Blade sharpness is based on the type of wood, peeled or unpeeled. Grit, dirt, etc will impact how long your blades stay sharp and is not covered under this warranty. When making a claim, you must show proof of purchase from an authorized distributor. This is valid only to the original buyer and not for tools sold secondhand, used or sold "as is" to a second party.

- ***WARNING: IF THE LOG COMES LOOSE OR UNCLAMPED WHILE MAKING A TENON, DO NOT DROP THE DRILL OR TRY TO GRAB THE LOG. HANG ON TO THE DRILL AND POINT IT IN A SAFE DIRECTION (usually toward the ground) AWAY FROM EVERYONE UNTIL IT COMES TO A COMPLETE STOP.***
- Do not remove the tool from the log until the drill comes to a complete stop. Failure to do so will wobble cut the tenon or cause harm to the operator. Do not place hands or body parts near the tool or blades while in operation.
- Do not drop or allow the tool to fall to the floor by itself or while in the drill. Doing so may bend the shank or damage the tool. This damage is not covered by the warranty.

MAINTENANCE:

It is best if you keep the tenon cutter body clean of sap & build up. Carefully clean the tool with the solvent or cleaner of your choice and dry when done. Wear all protective safety devices including safety glasses, gloves, etc. while cleaning tool.

Our blades are made from high-quality tool steel and may form oxidation. This is a natural occurrence and will vary depending on your geographic location, climate and shop environment, etc. You should periodically clean the blades and apply a thin film of oil. Every time you sharpen the blades you must also apply a thin film of oil. Use extreme caution when doing this so you don't cut yourself.

GETTING STARTED:

WARNING: Securing the log is probably the most important SAFETY factor that will arise while building log furniture.

- Obtain the log you want to tenon. Cut it to length and make sure the end is square.
- Secure the log in a vise or clamp it to a table in a V-shaped notch.
- Carefully install the tenon cutter into an unplugged 1/2" drill and tighten it firmly. A tee handle is also recommended.
- Anytime you adjust the blades or to retighten the chuck, you must always unplug the drill.

CUTTING TENONS:

- If the log diameter is greater than what the tool will accept use a drawknife to taper the end of the log like a "pencil" to get the tool started.
- With your log securely clamped, position the tenon cutter face squarely against the log you're going to tenon.
- DO NOT depress the trigger or start the drill before positioning it against the log. Doing so could harm yourself or the tool.
- While holding the drill squarely against the log, apply body pressure (straight in-line) with the drill and depress the trigger. Note: Apply quite a little force. Lean into the drill so that it does not jump around or skip off the log. See *Figure: 1*.
- DO NOT allow the drill to be stopped by the wood while making a tenon.
- You should now be cutting your tenon to the desired length.
- Once the cutting has begun, you may ease up on the pressure and the dual-blade technology will basically "pull" the tool into the log.

SAFETY:

GENERAL SAFETY RULES

- never operate this tool under the influence of alcohol, drugs or medication.
- you must wear safety glasses, dust mask and all other safety devices that are required.
- before installing/removing the tool, the drill must come to a complete stop and the power must be disconnected.
- do not wear gloves, loose clothing or other items that may get caught in the moving parts.
- never operate this tool in a drill press, lathe or any other device except for a 1/2" hand drill. Doing so voids the warranty.
- recommended RPMs is 500 or less, and we suggest a single-speed, gear-driven drill and not a variable-speed drill.
- overloading or exceeding the RPMs can result in annealing the blade or shank failure.
- the log must be secured in a vise or clamp before beginning. Failure to do so may cause bodily harm.
- do not run this tool into a nail, metal or foreign object. Doing so will ruin the blades or tool and voids the warranty.
- do not alter or misuse this tool in any fashion.
- remember the blades are sharp, use caution when handling.
- do not apply side force on the drill while in operation or it could result in premature shank failure or blade damage.

USING THE In-Sight Measurement System:

SAFETY continued:

- this tool must be maintained by keeping the blades sharp and clean of buildup.
- when excessive force is required to cut, sharpen or replace the blades. *A sharp tool is a safe tool!*
- under severe working conditions of dry or knotty hardwoods, or other natural stresses in the wood or overloading / side loading the tool may potentially cause the shank to fail or blade damage.

BLADE ASSEMBLY / SETTING:

- Insert the allen wrench (included) into the cap screw and loosen the bolt.
- Make sure the blade gap setting is the same distance apart for both blades, about 1/8"– 1/4".
- You can slightly change the tenon diameter by sliding the blade in or out. Sliding it in will reduce the diameter and sliding it back to increase the diameter. Do not slide it beyond 1/4" from the face of the cutout. Doing so will not cut a tenon, the blade must be exposed (see pg 5).
- The amount of "bite" or cut is preset at the factory and should not be shimmed.
- Securely tighten the cap screw but take caution not to strip it. Re-check both screws before starting.

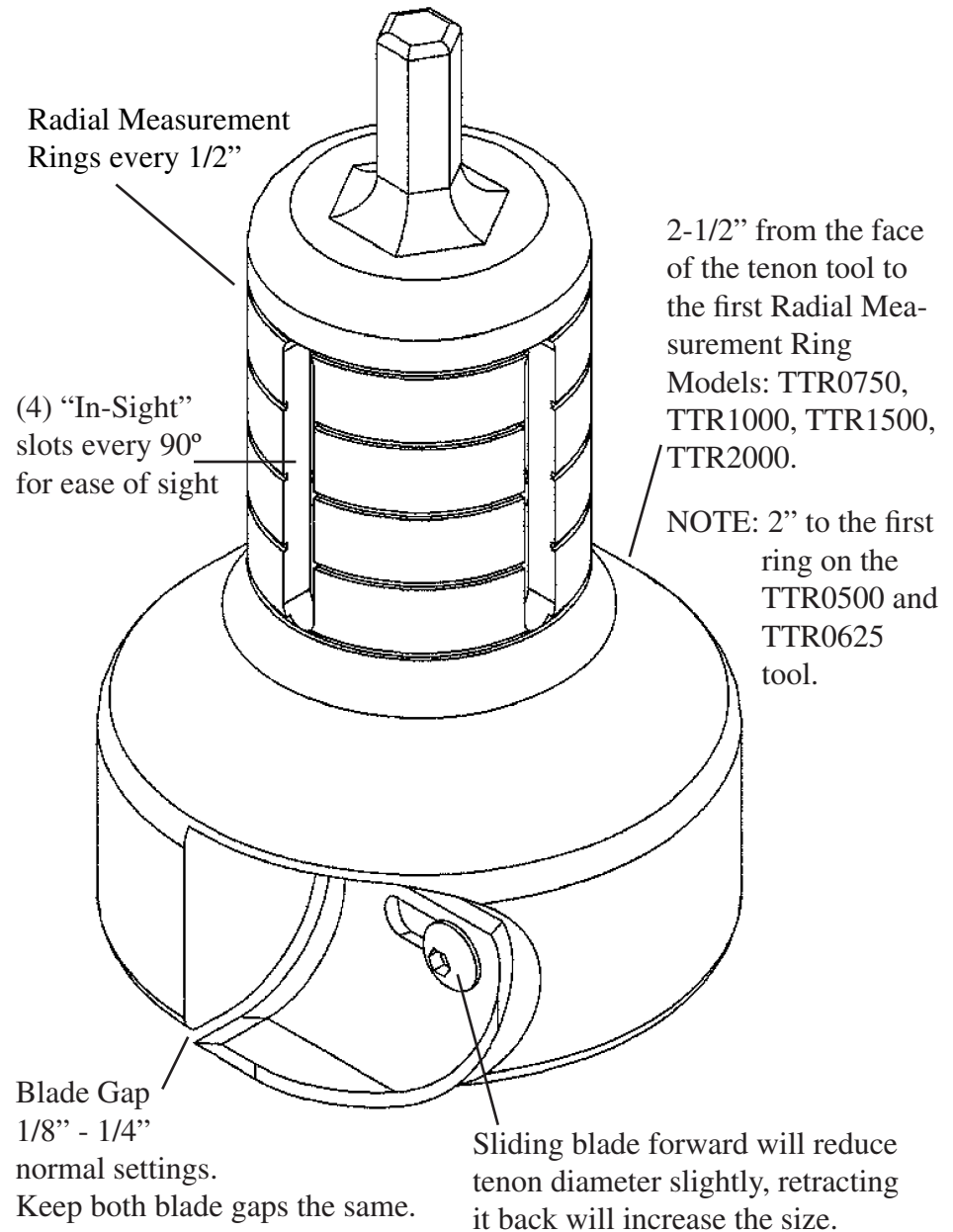

NOTE: *Do Not* slide it back more than 1/4" or it will not cut.